

Our machines are designed for outdoor use. We only use galvanised steel plate, and join the parts by means of clamp riveting and screwing in order to keep the surface layer intact. Edges are bent down, joints and seams overlap and many parts are embossed in order to prevent water penetration. The most exposed joints are also sealed with rubber strips or silicone. The products in the L-LINE are designed for plants with seasonal operations.

## KTG

The trench intake conveyor KTG is adapted in terms of capacity to transport material from a loading trench to a Skandia elevator. It can be finished with 15°, 30° or 45° incline. The trench intake section is self-regulating, which prevents overfilling.

### STANDARD EQUIPMENT:

- › Motor with chain drive
- › Self-regulating trench intake sections
- › Outlet for drive
- › Belt tensioner in tail end
- › Bottom clean out hatch in tail end
- › Intermediate trays with smooth finger joints
- › Permanently lubricated bearings
- › Chain of steel with flight of plastic

### ACCESSORIES:

- › Weather cover for motor
- › Direct-mounted gearbox motor with support frame
- › Weather cover for gearbox motor
- › Pop up overloading flap/inspection hatch with safety switch
- › Connections, hoppers & valves for different needs

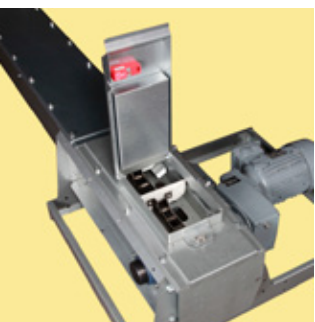

Pop up overloading flap/inspection hatch with safety switch.

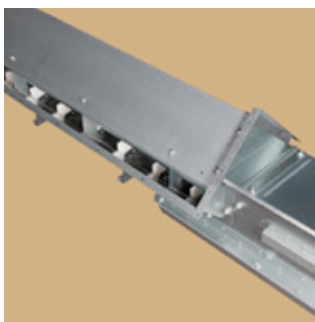

Self-regulating trench intake section.

**GALVANISED  
ENERGY EFFICIENT  
SERVICE FRIENDLY  
COMPACT  
RELIABLE  
EASILY MOUNTED**



**THE  
LEADING  
COMPANY**

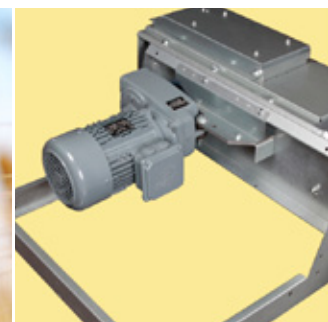

Direct-mounted gearbox motor with support frame.

# KTG DIMENSIONAL DRAWING

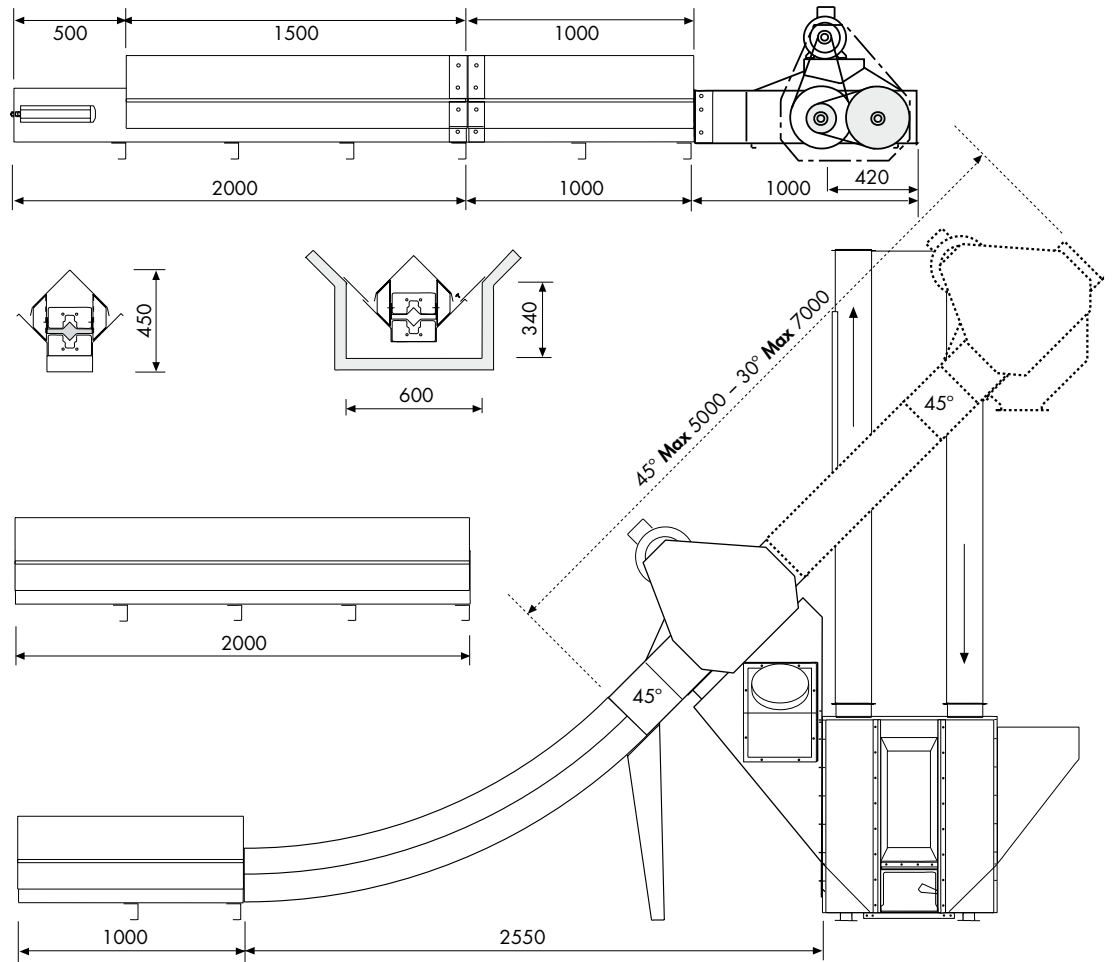

All drawings are available in CAD format.

## KTG

### TRENCH INTAKE CONVEYOR

		30 t/h	40 t/h	60 t/h
Capacity for 750 kg/m <sup>3</sup>	t/h	29	41	58
Capacity	m <sup>3</sup> /h	39	55	77
Speed	rpm	88	123	176
Chain speed	m/s	0.54	0.76	1.08
Conveyor chain, type			S45V	
Pitch/ultimate tensile strength			mm/33 kN	
Flight, qty/m chain	pcs	3	4	6
Flight, material			Plastic (Polythene)	
Chain sprocket, teeth			9	
Intermediate section, width/height	mm		200 (250)/245	
Plate thickness drive, tail end	mm		1.5 (2.0)	
Plate thickness intermediate section	mm		1.5	
Plate thickness Inlet and outlet hoppers	mm		1.25	
ATEX class (standard equipment)			II 3D/OD	

