

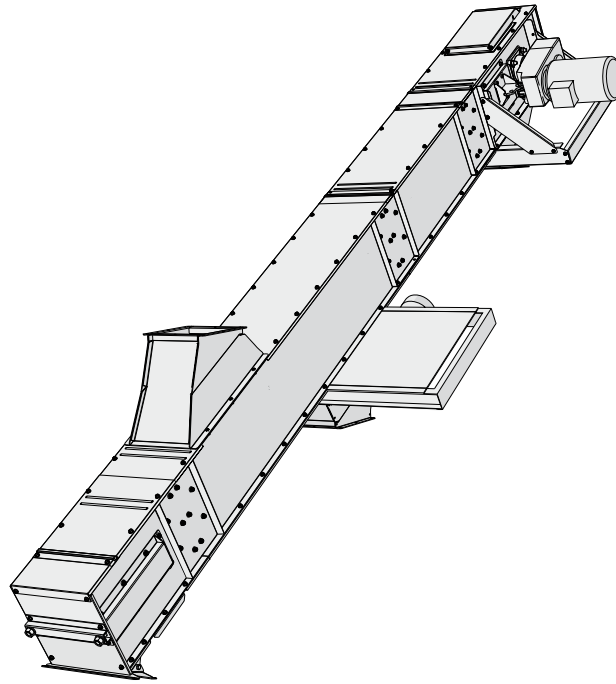

**SKANDIA
ELEVATOR**



Our machines are designed for outdoor use. We only use galvanised steel plate, and join the parts by means of clamp riveting and screwing in order to keep the surface layer intact. Edges are bent down, joints and seams overlap and many parts are embossed in order to prevent water penetration. The most exposed joints are also sealed with rubber strips or silicone. The products in the I-LINE are designed for plants with continuous operation all year round.

KTIA

The top conveyor KTIA is adapted in terms of capacity to transport material from a Skandia elevator to storage bins/silos. It is available with 15°, 30° or 45° incline.

STANDARD EQUIPMENT:

- › Direct-mounted gearbox motor with support frame
- › Overload sensor in outlet hopper
- › Inspection hatch with safety switch
- › Pop up overloading flap/inspection hatch with safety switch
- › Outlet hopper for the drive
- › Inlet hopper for tail end
- › Chain tensioner with variable end face for extra cleanliness
- › Bottom clean out hatch in tail end
- › Intermediate trays with smooth finger joints
- › Permanently lubricated bearings
- › Chain and flight of steel with flight casing of PE (polyethylene)

ACCESSORIES:

- › Weather cover for gearbox motor
- › Connections, hoppers & valves for different needs
- › Transverse outlet slide (in several drive variants)
- › Weather cover for outlet slide
- › Inspection glass for intermediate sections
- › Wire support for up to a 12 metre span

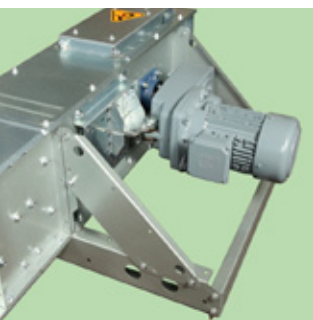

Direct-mounted gearbox motor with support frame.

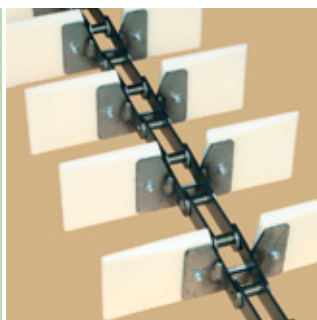

Chain and flight of steel with flight casing of PE (polyethylene).

**GALVANISED
ENERGY EFFICIENT
SERVICE FRIENDLY
COMPACT
RELIABLE
EASILY MOUNTED**



**THE
LEADING
COMPANY**

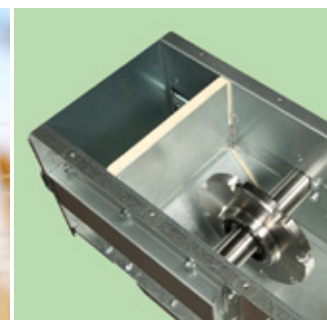

Variable end face for extra cleanliness.

KTIA DIMENSIONAL DRAWING

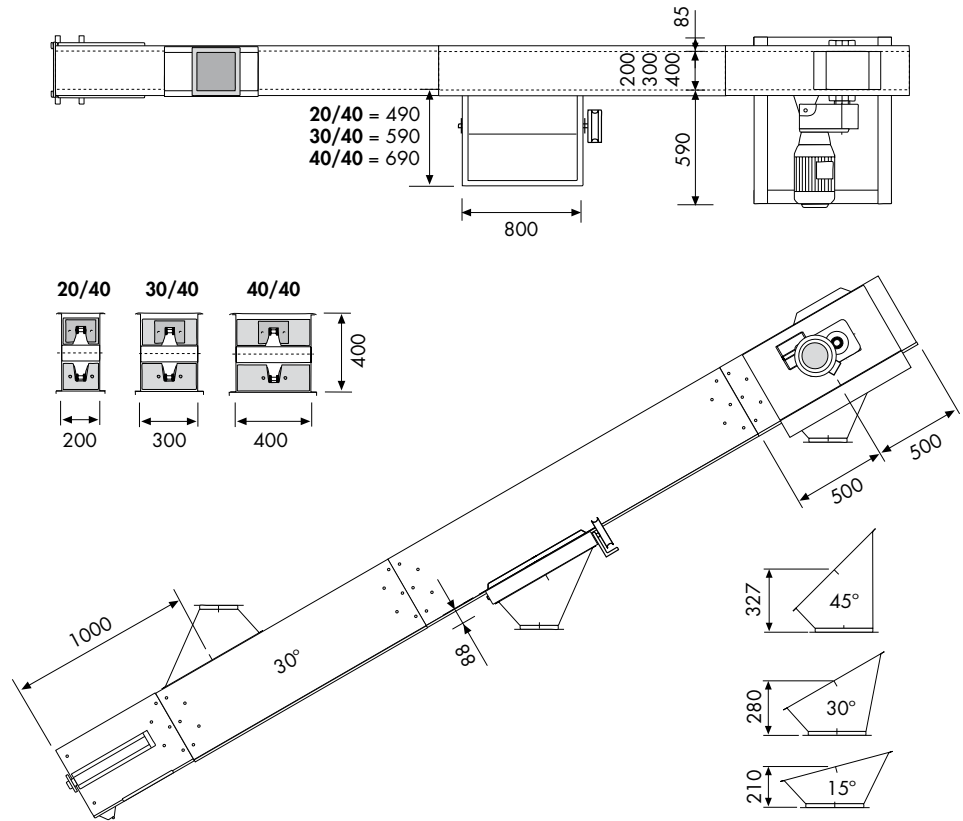

All drawings are available in CAD format.

KTIA TOP CONVEYOR

		20/40	20/40	30/40	40/40	40/40
		40 t/h	60 t/h	80 t/h	100 t/h	120 t/h
Capacity for 750 kg/m ³	t/h	49-51	65-67	88-92	109-117	129-133
Capacity	m ³ /h	65-68	87-89	117-123	145-156	172-177
Speed	rpm	48-50	64-66	58-61	54-58	64-66
Chain speed	m/s	0.64-0.67	0.85-0.88	0.77-0.81	0.72-0.77	0.85-0.88
Conveyor chain, type		M80				
Pitch/ultimate tensile strength		100 mm/80 kN				
Chain sprocket, teeth	pcs	8				
Flight, material		Plastic				
Intermediate section, width/height	mm	200/400		300/400		400/400
Plate thickness drive, side plate/bottom plate	mm	5.0/2.5				
Plate thickness tail end/intermediate section, side/bottom plate	mm	2.0/2.5				
Inlet and outlet hoppers	mm	3.0/□180		3.0/□250		3.0/□300
ATEX class (standard equipment)		II 2D/0D				

